

Installation

MULTICAL® 401

English



Kamstrup

Kamstrup A/S
Industrivej 28
DK-8660 Skanderborg
TEL: +45 89 93 10 00
FAX: +45 89 93 10 01
info@kamstrup.com
www.kamstrup.com

1. General conditions

⚠ Please read these instructions before installing the heat meter. Kamstrup's guarantee obligations do not apply in case of incorrect installation.

Please note the following installation requirements:

Gland meters	Flange meters only
Max. 16 bar	Max. 25 bar
All types of temperature sensors	Sensors with stainless steel pockets only

- Ambient temperature: 0-55°C
- Media temperature in flow sensor: 15°C...130°C

1.1 EMC conditions

MULTICAL® 401 has been designed and CE-marked for installation in housing units as well as in light industrial environments. All control cables must be drawn separately and not parallel to power cables. Control cables must be drawn with a min. distance of 25 cm to other installations.

2. Mounting of temperature sensors

Temperature sensors for measuring forward and return temperatures make out a matched pairs of sensors which must never be separated.

Usually MULTICAL® 401 is supplied with mounted temperature sensors. The cable length must neither be shortened nor lengthened.

The sensor marked with a red sign must be mounted in the forward pipe. The other sensor, which is marked with a blue sign, must be mounted in the return pipe.

2.1 Pocket-mounted sensor set

At an optimum sensor pockets are mounted in tee-pipes or 45° lateral Y-pieces. The tip of the sensor pocket must be placed in the middle of the flow pointing against the flow direction.

Temperature sensors should be inserted into the pockets as far as they can go. If a quick response time is required “non-hardening” heat conducting paste can be used.

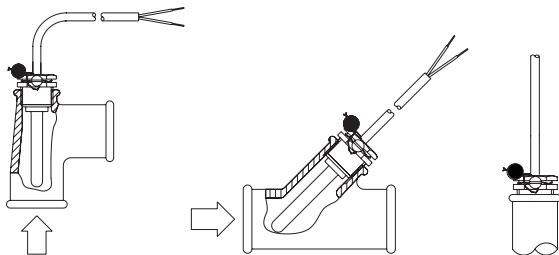

Place the small plastic tube on the sensor cables to face the cutout at the top of the pocket and secure the cable with the attached M4 brass screw. Fasten the screw with your fingers only. The pockets can then be sealed with seal and sealing wire.

2.2 Short direct temperature sensor set

The short direct sensor can be mounted in special ball valves or in special angle tee-pipes, both with threads up to R1 and a built-in M10 union for the short direct sensor.

For mounting in existing heating installations with standard angle tees Kamstrup A/S can, furthermore, supply R 1/2 and R 3/4 brass nipples which fit the short direct sensors.

In addition, please refer to paragraph 4 “Mounting of flow part”,

The short direct sensor can also be fitted into all flow part variants with a G3/4 and G1 thread on the meter case.

Fasten the brass unions of the sensors lightly (approx. 4 Nm) by means of a 12 mm face wrench, and then seal the sensors with seal and wire.

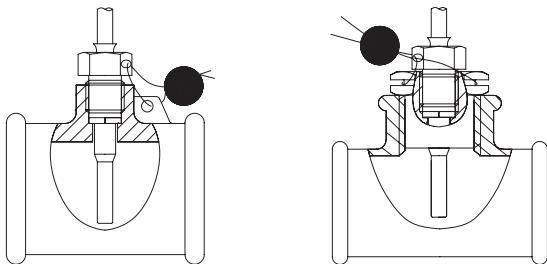

3. Information codes “E”

MULTICAL® 401 constantly monitors a series of important functions. If a serious error occurs in the measuring system or in the installation, an “E” appears in the left side of the display and an info-code can be read by activating the front key, until the measuring unit in the right side of the display shows “info”.

Info-code	Description	Response time
000	No irregularities	-
002	Flow sensor error	48 hours
008	Temperature sensor T1 outside measuring range	1...10 min
004	Temperature sensor T2 outside measuring range	1...10 min
016	Air in flow sensor	
128	Battery replacement	12 years

Short-period errors only release an “E” in the display, while the error exists.

If the error is still present after one hour, the info-code becomes permanent – however, not “info = 16”.

4. Mounting of flow part

Before mounting the flow part (flow sensor), flush the system thoroughly and remove protection plugs/plastic membranes from the flow sensor.

Correct flow sensor position (forward or return pipe) appears from the front label of MULTICAL® 401.

The flow direction is indicated by an arrow on the side of the flow sensor.

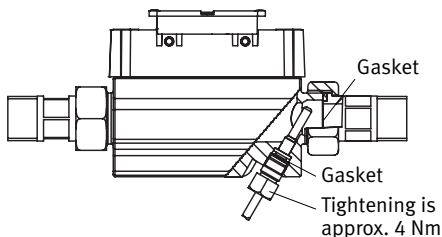

Glands and gaskets are to be mounted as shown in the above drawing.

MULTICAL® 401 up to 3 m³/h do not require straight inlet, whereas flow sensors ≥ 3.5 m³/h must be installed with straight inlet of 3...5 x DN. Class 2 MULTICAL® 401 up to 3 m³/h require straight inlet of min 5 x DN, whereas flow sensors ≥ 3.5 m³/h must be supplied with straight inlet of min. 10 x DN.

To prevent cavitation the operating pressure at the flow part must be min. 1.5 bar at q_p and min. 2.5 bar at q_s . This applies for temperatures up to approx. 80°C.

When the flow part has been mounted the water flow can be turned on. Open the valve on the inlet side of the meter first.

The flow part must not be exposed to pressures below ambient pressure (vacuum).

4.1 Mounting the flow part

The flow part can be mounted vertically, horizontally or at an angle.

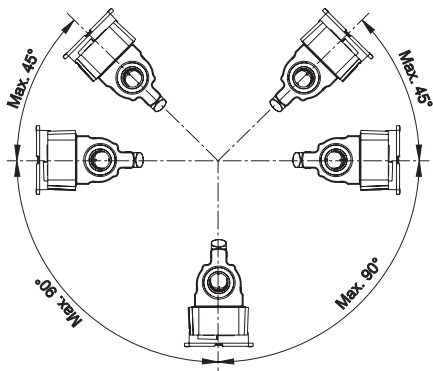
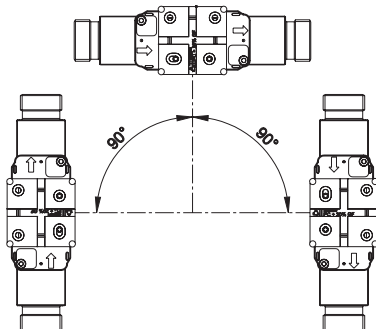

The flow part may be turned up to max. 45° and downwards for max. 90° in relation to the pipe axis.

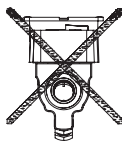

The flow part must not be mounted with the plastic box facing upwards.

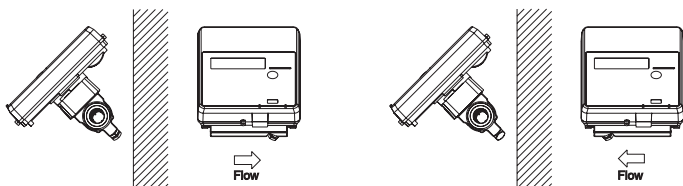

MULTICAL[®] 401 can be mounted on both sides of the flow part.

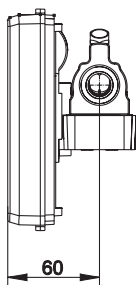

By moving the brackets MULTICAL[®] 401 can be mounted on the side of the flow part, thus reducing the built-in depth.

5. Mounting of calculator

5.1 Mounting

MULTICAL® 401 is mounted directly on the flow part (see point 4.1 “Mounting of flow part”) or directly on a plane wall.

Use the wall bracket as a template to mark/and drill two holes of 6 mm diameter on the wall. After mounting the calculator must be sealed with seal and wire.

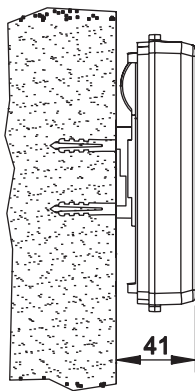

6. Power supply

MULTICAL® 401 can be power supplied by a built-in lithium battery, a 24 VAC/DC internal mains module or an internal 230 VAC mains module.

The two wires from battery or mains module are to be mounted in terminals 60 and 61 of the calculator

⚠ The polarity has to be correct; connect the red wire to terminal no. 60 (+) and the black wire to terminal no. 61 (-).

6.1 Battery supply

Connect MULTICAL® 401 to a lithium battery, D-cell. The battery is marked with the installation year, e.g. 2005, as well as production year.

The optimal battery life is obtained by keeping the battery temperature below 30°C, through wall mounting.

The voltage of a lithium battery is almost constant throughout the entire lifetime of the battery (approx. 3.65 V). Therefore, it is not possible to determine the remaining capacity by means of voltage measurement.

The battery cannot and must not be charged and must not be short-circuited. Used batteries must be handed in for approved destruction.

6.2 Mains modules

The modules are in protection class II and are connected via a two-wire cable (without earth) through the cable bush of the calculator placed in the right side of the bottom of the connection unit. Use connection cable with an outside diameter of 5–10 mm and be aware of correct dismantling as well as correct mounting of the cable relief.

Max. permitted fuse: 6 A

National installation regulations must be obeyed.

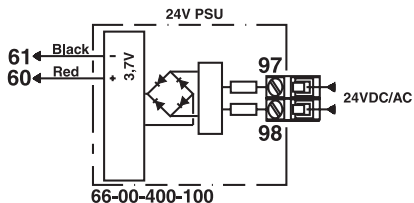

24 VAC/DC

A transformer must be used, e.g. type 66-99-401, for a 24 VAC/DC supply module.

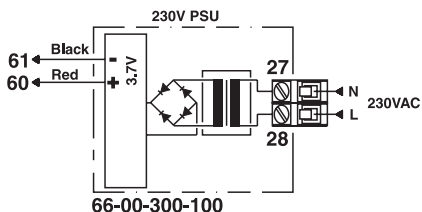

230 VAC

This module is used for direct mains connection.

7. Operational check

Carry out an operational check when the energy meter has been fully mounted. Open the thermo-regulators and cocks in order to establish a water flow through the heating system. Activate the push-button on MULTICAL® 401 and check that the display values of temperatures and water flow are probable.

8. Electrical connection

The polarity of the temperature sensors T1 and T2 is unimportant.

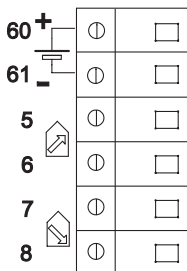

	Terminal no.	Standard heat
+	60	Supply (red)
-	61	Supply (black)
T1	5 - 6	Sensor in flow (red)
T2	7 - 8	Sensor in return (blue)

9. Plug-in modules

MULTICAL[®] 401 can be retrofitted with a series of extra functions in the form of plug-in modules. Below is a brief description of the individual modules.

9.1 Data/pulse inputs

E.g. the data terminals are used for connecting a PC or a MULTITERM hand-held terminal via an external reading plug which is connected as shown below.

65 - 66	Input A	$f < 0.5 \text{ Hz}$
67 - 68	Input B	$f < 0.5 \text{ Hz}$

62	Brown
63	White
64	Green

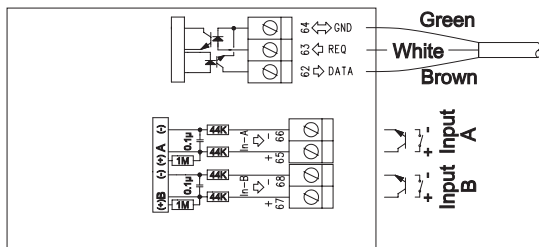

The signal is passive and galvanically separated through optocouplers. Conversion to RS232 level requires the connection of data cable 66-99-106 with above connections.

The pulse inputs can be used for connecting water meters. Please note that the max. pulse frequency and the correct pulse coding (l/pulse), which are selected by means of the FF and GG configuration.

9.2 Data/pulse output

The pulse output is used e.g. for remote counting of energy.

1 pulse is emitted per display count for energy, e.g. 1 pulse/kWh, when MULTICAL® 401 is programmed for a flow sensor of q_p 1.5 m³/h.

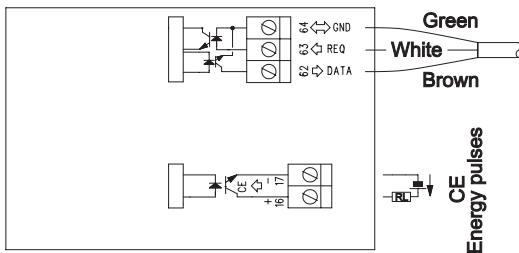

16 - 17	CE Energi	Config. FF must be set to "94"- "99" and GG to "00"	$I < 10 \text{ mA}$ $U < 30 \text{ V}$ Pulse duration 1 ms/30 ms/0.1 sec.
----------------	-----------	---	--

9.3 M-Bus/pulse inputs

M-Bus module can be mounted in star, ring, or bus topology.

M-Bus modules are available in two versions

- supporting primary addressing
- supporting primary and secondary addressing

The M-Bus network is to be connected to the terminals 24 and 25. The polarity is unimportant.

M-Bus module is available with pulse inputs.

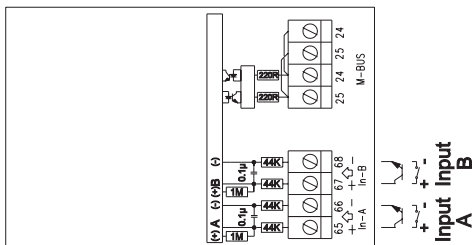

9.4 Radio/pulse inputs

The radio module is used for wireless communication via licence-free radio frequency, and is supplied for either internal or external antenna.

For further details on radio, please refer to *Technical Description for radio (5512-013 GB)*.

The pulse inputs in this module is identical with the earlier described.

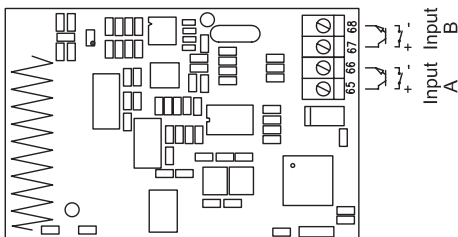

9.5 Modem

The modem module is connected directly to the standard telephone point without requiring extra power supply. When the module has been connected it must be checked that the voltage between terminals 70 and 71 is minimum 24 VDC.

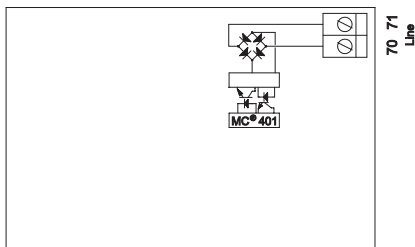

Always complete the installation by carrying out a “manual” call. By activating the front key for 10 sec., until a “Call” is displayed, the modem calls the selected telephone number (e.g. of the utility).

The service technician should always call the utility to ensure that the modem call has been registered.