



Model 950 Absorbance Monitor

Measures Cell
Growth



The Model 950 is Microprocessor Based and used with a Model BT65 Online Sensor to Measure Cell Density in Bacterial Fermentation and Cell Culture Applications

- Features proprietary bubble reject algorithm to minimize interference caused by aeration and agitation
- Measures absorbance up to 5 AU/OD units
- 4 X 20 character alphanumeric display and 6 button input for simple navigation
- Two 4-20mA analog outputs
- User-friendly menu based calibration
- Four configurable digital inputs and three optically isolated digital outputs can be connected to a PLC for inclusion in a control scheme
- Built-in diagnostics to report any system errors or alarms, including sensor failures, open cable and internal processor exceptions
- Baseline and baseline shift functions allow operator to manually set artificial zero point
- Advanced log amp provides improved response characteristics
- Front panel environmental protection level is rated at NEMA 4/IP65 - optional NEMA 4/IP65 field mount enclosures available

Model 950

Specifications

Signal Inputs	Single Channel Current from Model BT65 Online Sensor
Range	Up to 5 AU/OD
Accuracy	±1% of measurement range
Linearity	±1% of measurement range
Signal Outputs	General Alarm Relay Contact, 125mA 115Vac resistive load 2 - Process Relay Contact, 125mA 115Vac resistive load 2 - fully isolated 4-20mA, 1000 ohm load
Power	100 to 250Vac, 50/60Hz, 15VA, (Optional 18-36Vdc, 10W)
Operating Environment	Temperature 0-55°C; Relative Humidity 0-90%

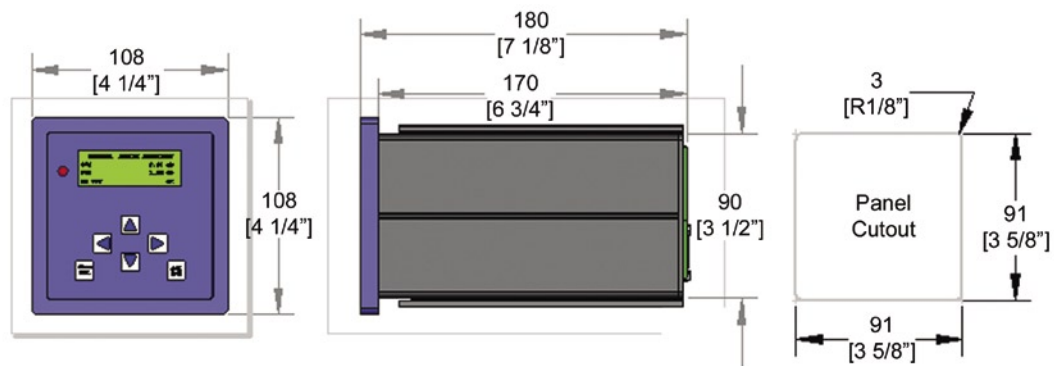

Dimensions Diagram

950			Order Code
	C	Line Power AC	
	D	24Vdc	
	A1	Analyzer Type Cell Growth	

Accessories



BT65 Sensor Cable	
A050-1065-10	Model 950 to BT65 cable - 10ft
A050-1065-15	Model 950 to BT65 cable - 15ft
A050-1065-25	Model 950 to BT65 cable - 25ft
A050-1065-50	Model 950 to BT65 cable - 50ft



